

Cutting data recommendations for PM tool steels

COLD WORK

PLASTIC MOULDING

HOT WORK

HIGH PERFORMANCE STEEL

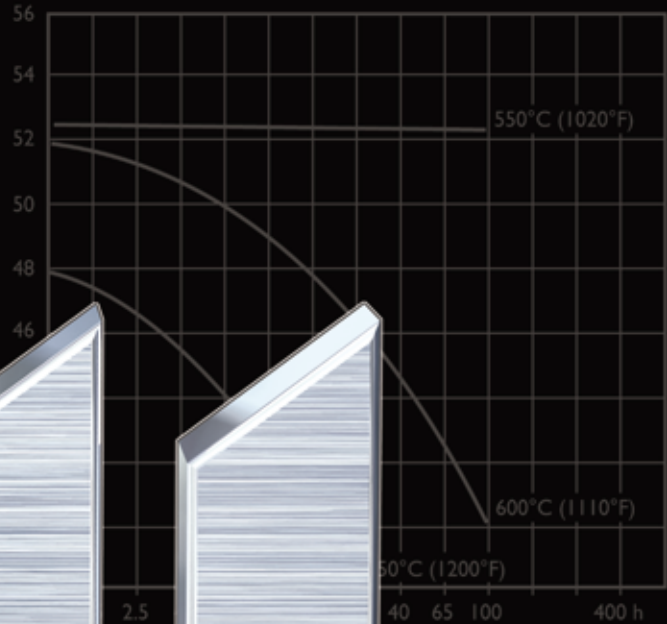
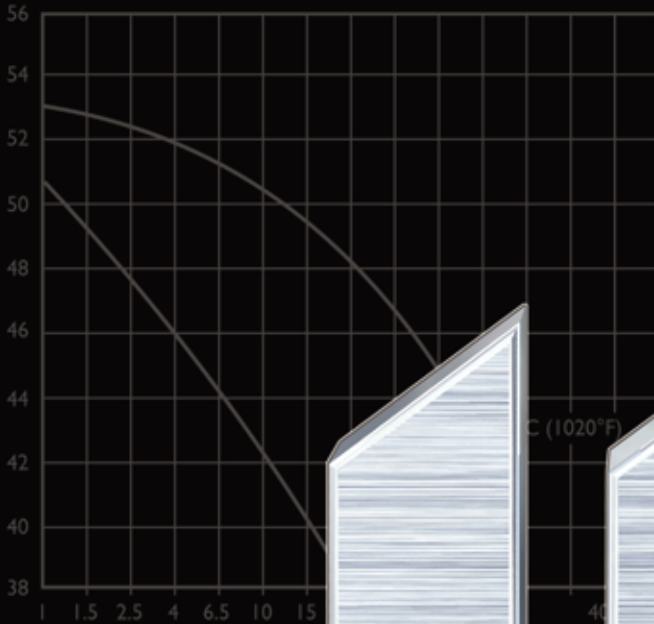

Typical analysis %	C 2,05
Standard specification	AISI D6, ()
Delivery condition	Soft annealed
Colour code	Red

Typical analysis %	Mn 0,8	Cr 4,5	W 0,2
Standard specification	D3) (W.Nr. 1.2796)		
Delivery condition	to approx. 200 HB		
Colour code	Red		

Temperature	20°C (68°F)	200°C (390°F)	400°C (750°F)
Density kg/m ³ lbs/m ³	7 770 0,281	7 670 0,277	7 650 0,275
Modulus of elasticity N/mm ² psi	194 000 28,1 × 10 ⁶	188 000 27,3 × 10 ⁶	178 000 25,8 × 10 ⁶
Coefficient of thermal expansion per °C from 20°C per °F from 68°F	to 100°C 11,7 × 10 ⁻⁶ to 212°F 6,5 × 10 ⁻⁶	to 200°C 12 × 10 ⁻⁶ to 400°F 6,7 × 10 ⁻⁶	to 400°C 13,0 × 10 ⁻⁶ to 750°F 7,3 × 10 ⁻⁶
Thermal conductivity W/m °C Btu in (ft ² h°F)	-	27 187	32 221
Specific heat K/kg °C Btu/lbs °F	455 0,109	525 0,126	608 0,145

Temperature	200°C (390°F)	400°C (750°F)
Density kg/m ³ lbs/m ³	7 670 0,277	7 650 0,275
Modulus of elasticity N/mm ² psi	194 000 28,1 × 10 ⁶	189 000 27,4 × 10 ⁶
Coefficient of thermal expansion per °C from 20°C per °F from 68°F	to 100°C 12,3 × 10 ⁻⁶ to 212°F 6,1 × 10 ⁻⁶	to 200°C 14 × 10 ⁻⁶ to 400°F 6,7 × 10 ⁻⁶
Thermal conductivity W/m °C Btu in (ft ² h°F)	20,5 142	21,5 149
Specific heat K/kg °C Btu/lbs °F	460 0,110	- -

Following cutting data recommendations are valid for Uddeholm Powder Metallurgical tool steels: **ELMAX, VANADIS 4, VANADIS 6, VANADIS 10, VANADIS 23, VANADIS 30 and VANADIS 60.** In case the value varies depending on tool steel grade, the steel grade and its value is specified.

Cutting data are always dependent on the actual operation, the machine tool and the cutting data used. The following cutting data are general guidelines that may have to be adjusted to the actual conditions of a specific machining operation.

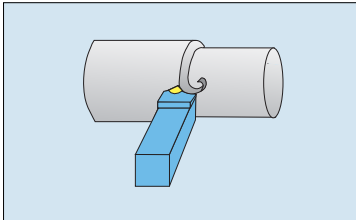

Turning

	Cemented carbide		High speed steel
	Roughing	Finishing	
Cutting speed (v_c), m/min			
ELMAX	70–120	120–140	10–14
VANADIS 4	100–150	150–200	12–15
VANADIS 6	70–100	100–120	8–10
VANADIS 10	50–80	80–100	5–8
VANADIS 23	110–160	160–210	12–15
VANADIS 30	80–110	110–140	10–15
VANADIS 60	60–90	90–110	6–10
Feed (f), mm/rev	0,3–0,6	–0,3	–0,3
Depth of cut (a_p), mm	2–6	–2	–2
Suitable grades	K20, P20 Coated CC	K15, P15 Coated CC	

Remarks

- Cutting fluid is recommended
- For turning with interrupted cut or face turning of large workpieces use a tougher cemented carbide grade.

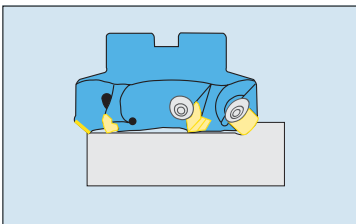

Face milling with cemented carbide

	Roughing	Finishing
Cutting speed (v_c), m/min		
ELMAX	80–110	110–140
VANADIS 4	90–120	120–150
VANADIS 6	50–70	70–100
VANADIS 10	30–50	50–70
VANADIS 23	110–130	130–160
VANADIS 30	60–80	80–110
VANADIS 60	40–60	60–80
Feed (f_z), mm/tooth	0,2–0,4	0,1–0,2
Depth of cut (a_p), mm	2–4	1–2
Suitable grades	K20, P20 Coated CC	K15, P15 Coated CC

Remarks

- Use a milling cutter with a positive–negative or positive–positive geometry.
- Climb milling should generally be used.
- Milling should generally be done without coolant. If a high surface finish is required coolant may be used.
- Cermet can be of use when finishing under stable conditions.

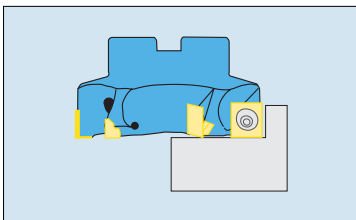

Square shoulder milling with cemented carbide

	a_e		
	0,1 x D	0,5 x D	1 x D
Cutting speed (v_c), m/min			
ELMAX	100–130	90–120	80–110
VANADIS 4	110–140	100–130	90–120
VANADIS 6	60–80	50–70	40–60
VANADIS 10	50–70	40–60	30–50
VANADIS 23	100–150	90–120	80–110
VANADIS 30	70–90	60–80	50–70
VANADIS 60	60–80	50–70	40–60
Feed (f_z), mm/tooth	0,25–0,3	0,15–0,2	0,1–0,15
Suitable grades	K20, P20 Coated CC		

Remarks

- Climb milling should generally be used.
- Choose the cutter diameter (D) and the radial depth of cut (a_e) so that at least two cutting edges are engaged simultaneously.
- If the machine tool power is inadequate, for the data given, reduce the depth of cut but do not reduce the feed.

End milling

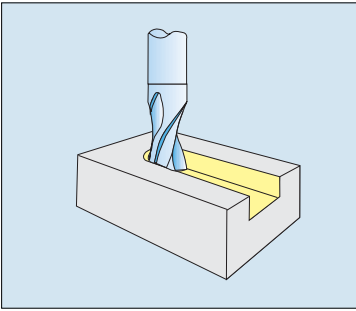

SLOT MILLING

		Cutter diameter (mm)				
		3-5	5-10	10-20	20-30	30-40
Uncoated HSS ¹⁻⁴⁾						
ELMAX	Cutting speed (v_c), m/min	5-8				
	Feed (f_z), mm/tooth	0,01-0,03	0,03-0,04	0,04-0,05	0,05-0,06	0,06-0,09
VANADIS 4, VANADIS 6, VANADIS 23	Cutting speed (v_c), m/min	5-8				
	Feed (f_z), mm/tooth	0,008-0,02	0,02-0,03	0,03-0,04	0,04-0,05	0,05-0,08
Coated HSS ¹⁻⁴⁾						
ELMAX	Cutting speed (v_c), m/min	14-16				
	Feed (f_z), mm/tooth	0,02-0,04	0,04-0,05	0,05-0,06	0,06-0,07	0,06-0,09
VANADIS 4, VANADIS 23	Cutting speed (v_c), m/min	14-18				
	Feed (f_z), mm/tooth	0,015-0,03	0,03-0,04	0,04-0,05	0,05-0,06	0,06-0,09
VANADIS 6 VANADIS 30	Cutting speed (v_c), m/min	12-16				
	Feed (f_z), mm/tooth	0,015-0,03	0,03-0,04	0,04-0,05	0,05-0,06	0,06-0,09
VANADIS 10, VANADIS 60	Cutting speed (v_c), m/min	10-14				
	Feed (f_z), mm/tooth	0,015-0,03	0,03-0,04	0,04-0,05	0,05-0,06	0,06-0,09
Solid cemented carbide ⁵⁻⁸⁾						
ELMAX	Cutting speed (v_c), m/min	50-60				
	Feed (f_z), mm/tooth	0,006-0,01	0,01-0,02	0,02-0,04		
VANADIS 4, VANADIS 23	Cutting speed (v_c), m/min	40-50				
	Feed (f_z), mm/tooth	0,006-0,01	0,01-0,02	0,02-0,04		
VANADIS 6 VANADIS 30	Cutting speed (v_c), m/min	35-45				
	Feed (f_z), mm/tooth	0,006-0,01	0,01-0,02	0,02-0,04		
VANADIS 10, VANADIS 60	Cutting speed (v_c), m/min	30-40				
	Feed (f_z), mm/tooth	0,006-0,01	0,01-0,02	0,02-0,04		
Indexable insert ⁶⁻⁷⁾						
ELMAX, VANADIS 4	Cutting speed (v_c), m/min	80-110				
	Feed (f_z), mm/tooth		0,06-0,08	0,08-0,10	0,10-0,12	
VANADIS 10	Cutting speed (v_c), m/min	30-50				
	Feed (f_z), mm/tooth		0,06-0,08	0,08-0,10	0,10-0,12	
VANADIS 23	Cutting speed (v_c), m/min	90-110				
	Feed (f_z), mm/tooth		0,06-0,08	0,08-0,10	0,10-0,12	
VANADIS 6 VANADIS 30	Cutting speed (v_c), m/min	70-90				
	Feed (f_z), mm/tooth		0,06-0,08	0,08-0,10	0,10-0,12	
VANADIS 60	Cutting speed (v_c), m/min	40-60				
	Feed (f_z), mm/tooth		0,06-0,08	0,08-0,10	0,10-0,12	
Suitable grades		K15, P20 Coated CC				

Remarks (slot and side milling)

- Climb milling is generally recommended.
- Use a cutter with chipbreaker when side milling with radial depths of cut, $a_e > 0,3 \times D$.
- When side milling (HSS) with small radial depths of cut the cutting speed can be increased by up to 15%.
- Use liberal amounts of cutting fluid.
- It is recommended to use a TiCN coated cutter when milling with solid cemented carbide tools.
- Climb milling is generally recommended.
- When side milling (CC) with small radial depths of cut the cutting speed can be increased by up to 30%.
- The radial run-out, at the cutting edges, must be small and not exceed 0,03 mm.

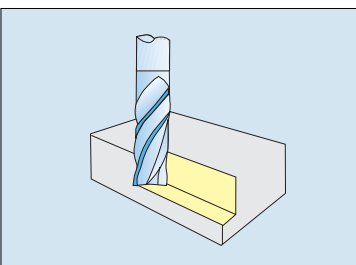

SIDE MILLING

For side milling the same cutting speed as for slot milling can be used, but the feeds must be adjusted in order to obtain a suitable average chip thickness.

Correction factor for side milling

Divide the cutter diameter (D) with the radial depth of cut (a_e). See in the chart below which correction factor (C_f) this corresponds to, and multiply the chosen feed (in the table for slot milling) with this factor.

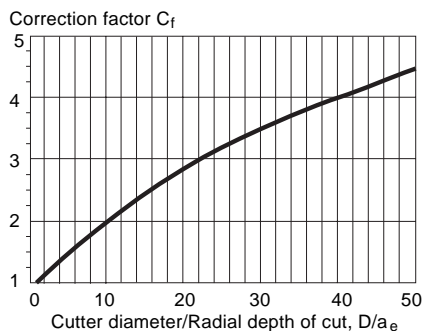

Example:

Tool: Cemented carbide insert
Cutter diameter: $D = 40$ mm
Radial depth of cut: $a_e = 2$ mm
 $D/a_e = 40/2 = 20$

Feed according to table slot milling = 0,11 mm/tooth
Correction factor according to chart: $C_f = 2,8$

Feed for side milling:
 $f_z = 2,8 \times 0,11 = 0,31$ mm/tooth

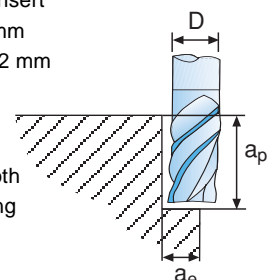

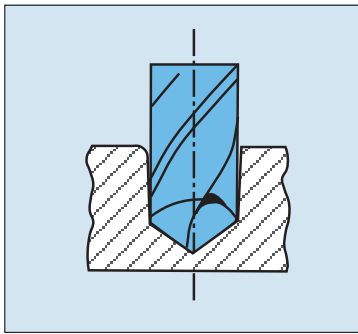

Drilling

		Drill diameter (mm)				
		3-5	5-10	10-20	20-30	30-40
Uncoated HSS ¹⁻²⁾						
ELMAX	Cutting speed (v_c), m/min	10-12				
	Feed (f), mm/rev	0,05-0,15	0,15-0,25	0,25-0,35	0,35-0,40	0,40-0,45
VANADIS 4, VANADIS 23	Cutting speed (v_c), m/min	10-12				
	Feed (f), mm/rev	0,05-0,10	0,10-0,20	0,20-0,30	0,30-0,35	0,35-0,40
VANADIS 6 VANADIS 30	Cutting speed (v_c), m/min	8-10				
	Feed (f), mm/rev	0,05-0,10	0,10-0,20	0,20-0,30	0,30-0,35	0,35-0,40
VANADIS 10 VANADIS 60	Cutting speed (v_c), m/min	6-8				
	Feed (f), mm/rev	0,05-0,10	0,10-0,20	0,20-0,30	0,30-0,35	0,35-0,40
Coated HSS ¹⁻³⁾						
ELMAX	Cutting speed (v_c), m/min	18-20				
	Feed (f), mm/rev	0,07-0,18	0,18-0,30	0,30-0,40	0,40-0,45	0,45-0,50
VANADIS 4, VANADIS 23	Cutting speed (v_c), m/min	16-18				
	Feed (f), mm/rev	0,07-0,18	0,18-0,25	0,25-0,35	0,35-0,40	0,40-0,45
VANADIS 6 VANADIS 30	Cutting speed (v_c), m/min	14-16				
	Feed (f), mm/rev	0,07-0,18	0,18-0,25	0,25-0,35	0,35-0,40	0,40-0,45
VANADIS 10 VANADIS 60	Cutting speed (v_c), m/min	12-14				
	Feed (f), mm/rev	0,07-0,18	0,18-0,25	0,25-0,35	0,35-0,40	0,40-0,45
Indexable insert ⁴⁻⁵⁾ cem. carbide insert						
ELMAX VANADIS 6	Cutting speed (v_c), m/min	90-120				
	Feed (f), mm/rev	0,05-0,10 0,10-0,15				
VANADIS 4, VANADIS 30	Cutting speed (v_c), m/min	100-130				
	Feed (f), mm/rev	0,05-0,10 0,10-0,15				
VANADIS 10	Cutting speed (v_c), m/min	70-90				
	Feed (f), mm/rev	0,05-0,10 0,10-0,15				
VANADIS 23	Cutting speed (v_c), m/min	120-150				
	Feed (f), mm/rev	0,05-0,10 0,10-0,15				
VANADIS 60	Cutting speed (v_c), m/min	80-100				
	Feed (f), mm/rev	0,05-0,10 0,10-0,15				
Solid cemented carbide ⁶⁻⁸⁾						
ELMAX, VAN. 4, VAN.23	Cutting speed (v_c), m/min	60-80				
	Feed (f), mm/rev	0,08-0,10	0,10-0,20	0,20-0,30	0,30-0,35	
VANADIS 6 VANADIS 30	Cutting speed (v_c), m/min	50-70				
	Feed (f), mm/rev	0,08-0,10	0,10-0,20	0,20-0,30	0,30-0,35	
VANADIS 10 VANADIS 60	Cutting speed (v_c), m/min	40-60				
	Feed (f), mm/rev	0,08-0,10	0,10-0,20	0,20-0,30	0,30-0,35	
Brazed cemented carbide ⁶⁻⁸⁾						
ELMAX	Cutting speed (v_c), m/min	30-35				
	Feed (f), mm/rev	0,15-0,25	0,25-0,35	0,35-0,40		
VANADIS 4 VANADIS 23	Cutting speed (v_c), m/min	30-40				
	Feed (f), mm/rev	0,15-0,25	0,25-0,35	0,35-0,40		
VANADIS 6 VANADIS 30	Cutting speed (v_c), m/min	25-35				
	Feed (f), mm/rev	0,15-0,25	0,25-0,35	0,35-0,40		
VANADIS 10 VANADIS 60	Cutting speed (v_c), m/min	20-30				
	Feed (f), mm/rev	0,15-0,25	0,25-0,35	0,35-0,40		

Remarks

- 1) The cutting fluid should be ample and directed at the tool.
- 2) When drilling with short "NC-drills" the feed may be increased by up to 20%. For extra long drills the feed must be decreased.
- 3) TiCN-coating is recommended when drilling with coated HSS.
- 4) Use insert grades in the range of ISO P20-P30. Under unstable conditions a tougher carbide grade should be used for the centre position.
- 5) Use a high cutting fluid pressure and flow rate for a good chip removal.
- 6) If machining with solid or brazed cemented carbide drills, a rigid set-up and stable working conditions are required.
- 7) The use of drills with internal cooling channels is recommended.
- 8) Use a cutting fluid concentration of 15-20%.

Tapping with HSS

ELMAX VANADIS 6 VANADIS 30	Cutting speed (v_c) = 5-7 m/min
VANADIS 4 VANADIS 23	Cutting speed (v_c) = 8-10 m/min
VANADIS 10 VANADIS 60	Cutting speed (v_c) = 4-6 m/min

Remarks

- Threading compound or cutting oil is recommended.
- Forming tap (non-cutting) is recommended.

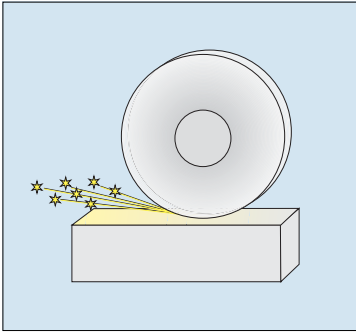

Grinding of PM tool steel

For the majority of grinding operations of PM tool steels, boron nitride wheels are the best choice for such steels. Where boron nitride wheels cannot be used, the type of grinding wheel must be chosen with care.

Fine crystalline aluminium oxide wheels, such as Norton SG, give good results if the grinding set up is rigid. A mixture of fine crystalline and conventional aluminium oxide wheels, such as Norton SGB and SlipNaxos 210A and 420A, are also recommended.

The recommendations in the following table have been made in consultation with grinding wheel manufacturers, and are based on our own and others' experience. However, it must be emphasised that the choice of grinding wheel is strongly dependent on the type of grinding machine, rigidity of clamping and the size of the workpiece, which means that the recommendations below should be seen as starting points, from which each particular process should be optimized.

The grinding wheels are of SlipNaxos¹⁾, Tyrolit²⁾, Norton³⁾ and Universal⁴⁾ type. The designations, however, essentially comply with international standards.

Uddeholm grade	Condition	Centerless	Surface grinding straight wheel	Surface grinding segment	Cylindrical grinding	Internal grinding	Profile grinding
VANADIS 4 VANADIS 6 VANADIS 10 VANADIS 23 VANADIS 30 VANADIS 60 ELMAX	Soft annealed	33A 60 L VM ¹⁾	43A 46 H VX ¹⁾ 91A 46 2 I 8 V 111 ²⁾ 25A 46 JVT ³⁾ WA 46 HV ⁴⁾	43A 36 F VX ¹⁾ 89A 30 1 I 10A V 237 P 20 ²⁾ 53A 30 F 12 VBEP ³⁾ WA 24 GV ⁴⁾	77A 60 K VX ¹⁾ 89A 60 2 K 5A V217 ²⁾ 25A 46 LVT ³⁾ 48A 46 LV ⁴⁾	77A 60 K9 VX ¹⁾ 89A 60 2 J6 V 111 ²⁾ 32A 46 L5 VBE ³⁾ WA 46 JV ⁴⁾	42A 100 I VX ¹⁾ 89A 60 2 I 6 V 111 ²⁾ 25A 100 LVT ³⁾ WA 100 LV ⁴⁾
VANADIS 23 VANADIS 30	Hardened	48A 60 L VX ¹⁾ 820A 60 L VZ ¹⁾	B151 R50 B3 ¹⁾ 48A 46 H VX ¹⁾ 415A 46 G VZ ¹⁾ B126 C 50 B54 BA ²⁾ 93A 46 H8A V217 ²⁾ 3SG 46 HVX ³⁾ SGB 46 HVX ³⁾ 27A 46 HV ⁴⁾	415A 46 F VZP ¹⁾ 89A 30 1 I 10A V237 P20 ²⁾ 3SG 36 HVX ³⁾ WA 36 HV ⁴⁾	B151 R50 B3 ¹⁾ 48A 60 K VX ¹⁾ 415A 60 J VZ ¹⁾ B126 C75 B54 BA ²⁾ 92A 60 1 J5A V237 ²⁾ 3SG 60 KVX ³⁾ SGB 60 KVX ³⁾ 27A 60 JV ⁴⁾	B151 R75 B3 ¹⁾ 820A 80 K9 VZ ¹⁾ B126 C75 B54 BA ²⁾ 91A 60 1 J6 V111 ²⁾ 3SG 60 JVX ³⁾ 27A 60 HV ⁴⁾	B126 R100 B6 ¹⁾ 820A 1003 G VZ ¹⁾ B126 C75 B53 ²⁾ B126 G3 ²⁾ 97A 60 1 G10 - A V257 P23 ²⁾ 61B 91 L5 V D49 ²⁾ 5SG 80 KVX ³⁾ 27A 100 JV ⁴⁾
VANADIS 4 VANADIS 6 VANADIS 10 VANADIS 60 ELMAX	Hardened	48A 60 L VX ¹⁾ 820A 60 L VZ ¹⁾	B151 R50 B3 ¹⁾ 48A 46 H VX ¹⁾ 210A 46 G VZ ¹⁾ B126 C 50 B54 BA ²⁾ 93A 46 H8A V217 ²⁾ 3SG 46 GVX ³⁾ SGB 46 HVX ³⁾ 27A 46 HV ⁴⁾	415A 46 F VZP ¹⁾ 89A 30 1 I 10A V237 P20 ²⁾ 3SG 46 F VSPF ³⁾ WA 46 FV ⁴⁾	B151 R50 B3 ¹⁾ 48A 60 K VX ¹⁾ 210A 60 J VZ ¹⁾ B126 C75 B54 BA ²⁾ 92A 60 1 J5A V237 ²⁾ 5SG 70 IVX ³⁾ SGB 60 KVX ³⁾ 27A 60 IV ⁴⁾	B151 R75 B3 ¹⁾ 820A 80 K9 VZ ¹⁾ B126 C75 B54 BA ²⁾ 91A 60 1 J6 V111 ²⁾ 3SG 60 JVX ³⁾ 27A 60 HV ⁴⁾	B126 R100 B6 ¹⁾ 820A 1003 G VZ ¹⁾ B126 C75 B53 ²⁾ B126 G3 ²⁾ 97A 60 1 G10 - A V257 P23 ²⁾ 61B 91 L5 V D49 ²⁾ 5SG 80 JVX ³⁾ 27A 100 IV ⁴⁾

Remarks

- The grinder must be vibration-free, rigid and in good condition.
- The workpiece must be securely clamped. Use a steady rest when grinding long, thin work pieces.
- Use sharp conical diamonds when dressing Al₂O₃ wheels. The dressed finish must be rough.
- Maintain a high peripheral speed of grinding wheels.
- Ensure an adequate supply of coolant to the grinding zone.
- If grinding is carried out without a coolant, select a grinding wheel that is one grade softer than would have been used if grinding was performed with coolant.
- Never grind a hardened workpiece before it has been tempered.

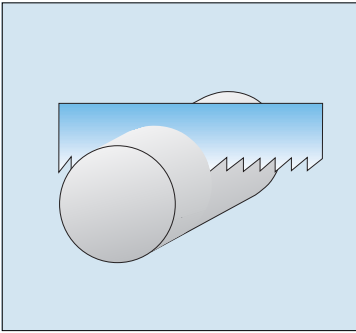

Bandsawing

The general recommendation is to use bimetal bandsaw blades with variable tooth pitch and tips made of HSS M51. The high cobalt and molybdenum content in M42 give high resistance to both heat and wear.

Carbide tipped bandsaw blades can be used in modern machines in good condition and when the clamping of the workpiece is rigid.

Uddeholm grade	Cutting speed (v_c)	Tooth pitch
ELMAX VANADIS 4 VANADIS 23 VANADIS 30	With HSS = 25–35 m/min With carbide = 50–60 m/min	< 50 mm contact length = 4/6 tooth/inch 50–150 mm contact length = 3/4 tooth/inch >150 mm contact length = 2/3 tooth/inch
VANADIS 6 VANADIS 10 VANADIS 60	With HSS = 20–30 m/min With carbide = 40–60 m/min	

Remarks

- In order to achieve the full life, we recommend running-in the bandsaw blades. A new bandsaw blade should only be used with 50% of the normal feed for about 10–15 minutes.
- Coolant should always be used for better tool life and surface finish.
- Make sure about enough chip space when sawing large cross sections. Use coarse pitch.
- At least two teeth should be in contact with the work piece at all times during sawing. In other cases use finer pitch.

Cutting data formulae

TURNING

$$\text{Cutting speed, } v_c = \frac{\pi \times D \times n}{1000} \text{ (m/min)}$$

$$\text{Spindle speed, } n = \frac{1000 \times v_c}{\pi \times D} \text{ (rev/min)}$$

$$\text{Material removal rate, } Q = v_c \times a_p \times f \text{ (cm}^3\text{/min)}$$

$$\text{Surface roughness, } R_a \approx \frac{f^2 \times 50}{r_\epsilon} \text{ (\mu m)}$$

MILLING

$$\text{Cutting speed, } v_c = \frac{\pi \times D \times n}{1000} \text{ (m/min)}$$

$$\text{Spindle speed, } n = \frac{1000 \times v_c}{\pi \times D} \text{ (rev/min)}$$

$$\text{Table speed, } v_f = f_z \times n \times z = f \times n \text{ (mm/min)}$$

$$\text{Average chip thickness, } h_m = f \times \sqrt{\frac{a_e}{D}} \text{ (mm),}$$

valid for $\frac{a_e}{D} < 0,3$

$$\text{Material removal rate, } Q = \frac{a_p \times a_e \times v_f}{1000} \text{ (cm}^3\text{/min)}$$

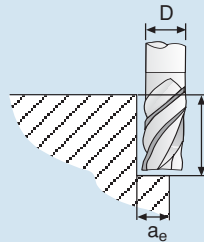

DRILLING

$$\text{Cutting speed, } v_c = \frac{\pi \times D \times n}{1000} \text{ (m/min)}$$

$$\text{Spindle speed, } n = \frac{1000 \times v_c}{\pi \times D} \text{ (rev/min)}$$

$$\text{Feed speed, } v_f = f \times n \text{ (mm/min)}$$

$$\text{Feed per rev., } f = \frac{v_f}{n} \text{ (mm/rev)}$$

Legend:

a_e = radial depth of cut (mm)

a_p = axial depth of cut (mm)

D = work piece dia. \varnothing (mm)—turning

= cutter dia. \varnothing (mm)—milling

= drill dia. \varnothing (mm)—drilling

f = feed per rev. (mm/rev)

f_z = feed per tooth (mm/tooth)

h_m = average chip thickness (mm)

n = spindle speed (rev/min)

Q = material removal rate (cm³/min)

R_a = surface roughness (μ m)

r_ϵ = nose radius (mm)

v_c = cutting speed (m/min)

v_f = feed speed (mm/min)

z = number of teeth